

TRS - 1 Speed

With the TRS universal vegetable slicer it is possible to quickly and easily make over 70 different types of cuts for the stylish and imaginative presentation of salads, garnishings, macedoines, chips and many other combinations.

FEATURES

- Wide range of functions: slicing, mincing, grating, shredding and cutting into chips or cubes of all sizes.
- Plate speed at 360 RPM for precise cutting, slicing and dicing.
- Large round hopper (215cm²) allows food of greater dimension to be processed.
- Feeding arm with integrated long-vegetable hopper (tube pusher), 60mm in diameter. Ideal for carrots, zucchini, cucumbers, etc.
- Base inclined at 20° provides easy loading and unloading.
- High discharge zone permits the use of deep GN containers (up to 20cm).
- Feeding arm and hopper are made entirely in stainless steel. Aluminium motor housing.
- Plates and ejector may be removed in seconds by opening the cover.
- All parts that come into contact with the food are in stainless steel or plastic, can be removed for easy cleaning and are dishwasher safe.

Vegetable slicers



DITO

Electrolux

- Sleek, compact and innovative design. Rounded corners allow for easy cleaning.
- IP55 touch-control, waterproof panel. Green button indicates ON, Red button indicates OFF. Pulse control for precise slicing.
- Asynchronous industrial motor with no brushes for high reliability and quiet functioning. Stainless steel motor shaft.
- Two separate safety switches stop the machine in order to protect the operator from potentially dangerous conditions. One senses when the handle is lifted and/or the shaft is removed and the other senses when the cover is opened.
- IP24 throughout entire machine.

Specifications

MODEL	TRS1V501G 603357
External dimensions - mm	
width	252
depth	500
height	502
Cutting capacity - kg/h	
carrots	250
chips	500
dicing	450
Cutting capacity - kg/h	
potatoes	250
Power - kW	
installed-electric	0.5
Net weight - kg.	21.4
Supply voltage	220...240 V, 1N, 50



DITO**Electrolux**

Optional accessories

CODE	DESCRIPTION	
653565	*NOT TRANSLATED*	✓
653566	*NOT TRANSLATED*	✓
653567	*NOT TRANSLATED*	✓
653568	*NOT TRANSLATED*	✓
653569	*NOT TRANSLATED*	✓
653570	*NOT TRANSLATED*	✓
653571	*NOT TRANSLATED*	✓
653572	*NOT TRANSLATED*	✓
653573	*NOT TRANSLATED*	✓
653122	DISC WITH CORRUGATED BLADES 2 MM	✓
653123	DISC WITH CORRUGATED BLADES 3 MM	✓
653126	DISC WITH CORRUGATED BLADES 6 MM	✓
653111	DISC WITH CURVED BLADES 1 MM	✓
653511	DISC WITH CURVED BLADES 10 MM	✓
653112	DISC WITH CURVED BLADES 2 MM	✓
653113	DISC WITH CURVED BLADES 3 MM	✓
653115	DISC WITH CURVED BLADES 5 MM	✓
653162	GRATING DISC 2 MM	✓
653163	GRATING DISC 3 MM	✓
653164	GRATING DISC 4 MM	✓
653167	GRATING DISC 7 MM	✓
653498	GRATING DISC 9 MM	✓
653008	GRATING DISC FOR KNODELN AND BREAD	✓
653170	GRATING DISC FOR PARMESAN AND BREAD	✓
653283	S/S WORK TABLE+FOLDING SHELVES+DISK RACK	✓
653214	SHREDDING DISC 2X2 MM	✓
653153	SHREDDING DISC 3X3 MM	✓
653154	SHREDDING DISC 4X4 MM	✓
653289	SLICING BLADES VARIABLE DEPTH 1MM-7MM	✓
653101	SLICING DISC WITH STRAIGHT BLADES 1 MM	✓
653110	SLICING DISC WITH STRAIGHT BLADES 10 MM	✓
653185	SLICING DISC WITH STRAIGHT BLADES 14 MM	✓
653102	SLICING DISC WITH STRAIGHT BLADES 2 MM	✓
653103	SLICING DISC WITH STRAIGHT BLADES 3 MM	✓
653106	SLICING DISC WITH STRAIGHT BLADES 6 MM	✓
653108	SLICING DISC WITH STRAIGHT BLADES 8 MM	✓
653180	TABLE+SHELF+GN 1/1 POLYCARBONATE TRAY	✓



DITO

Electrolux

Installation drawings

603357

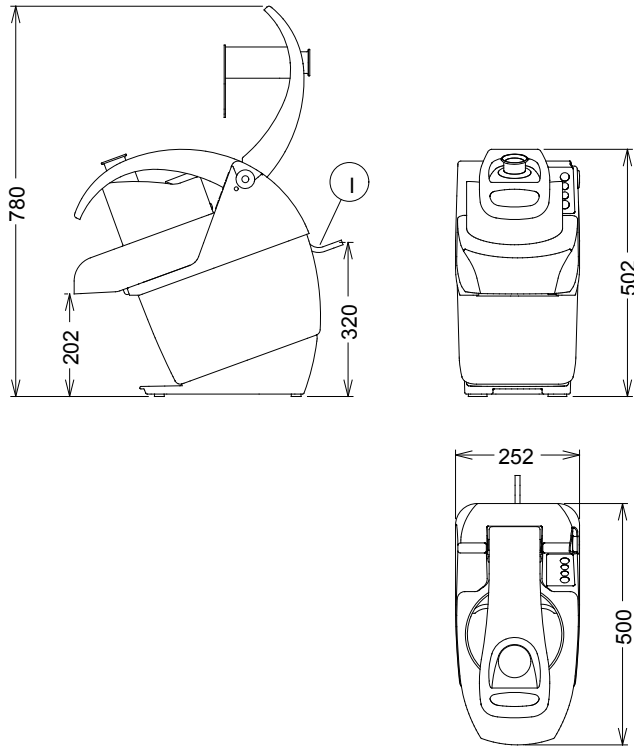

MODEL

I - Electrical connection

**TRS1V501G
603357**

220...240 V, 1N, 50



www.dito-electrolux.com

Vegetable slicers

AAAC015

